

Powered by



TPL 121000T ▶ 12V 100Ah

TPL 121000T is a front access design with an upgraded degassing system, up to 12 years expected life. As with all CSB batteries are rechargeable, highly efficient, leak proof and maintenance free.



► Specification

Cells Per Unit	6
Voltage Per Unit	12
Capacity	100Ah @ 8hr-rate to 1.75V per cell @25°C (77°F)
Weight	Approx. 32.7kg (72.09 lbs)
Maximum Discharge Current	300A(1min)
Internal Resistance	Approx. 5.0 mΩ
Operating Temperature Range	Discharge: -15°C~50°C (5°F~122°F) Charge: -15°C~40°C (5°F~104°F) Storage: -15°C~40°C (5°F~104°F)
Nominal Operating Temperature Range	25°C±3°C(77°F±5°F)
Float Charging Voltage	2.275 ± 0.025V / Cell at 25 °C (77°F) Temp. Coefficient ±3.3mV/°C(±1.8mV/°F)
Recommended Maximum Charging Current Limit	30A
Equalization / Cycle Use Charging Voltage	2.45V Temps coefficient ±0.05mV/°C(±1.8mV/°F)
Terminal	I2-Thread lead alloy recessed terminal to accept M6 bolt
Terminal Hardware Initial Torque	120-in-lbs.(13.58 N-m)
Container Material	ABS(UL94-V0)&(UL94-HB) / L.O.I higher than 28
Configurable Degassing Accessory	Degassing kit for option * Only with CSB approved degassing kit *



CSB-manufactured VRLA batteries are UL-recognized components under UL1989.
CSB is also certified by ISO 9001 and ISO 14001.

► Dimensions :

Unit: mm (inch)

Overall Height (H)	Length (L)	Width (W)
280.0±2.5 (11.02± 0.1)	390±2.5 (15.35±0.1)	105±1.5 (4.13±0.06)

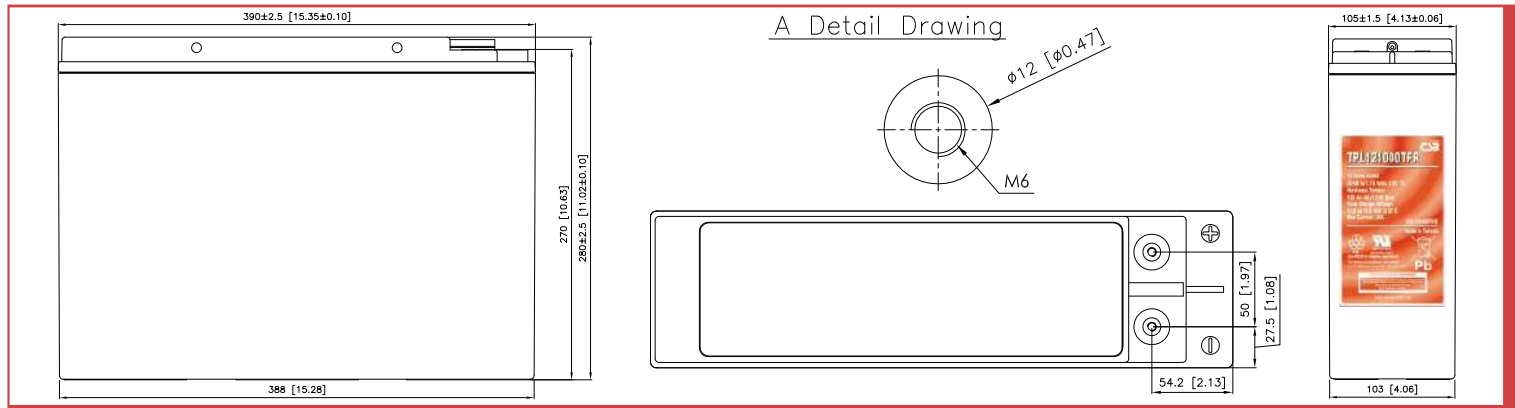

Constant Current Discharge Characteristics Unit:A (25°C ,77°F)

F.V/Time	15MIN	30MIN	60MIN	90MIN	2HR	3HR	4HR	5HR	8HR	10HR	20HR
1.60V	209	125	73.0	53.2	42.2	29.9	23.6	19.5	13.0	10.8	5.59
1.67V	203	123	72.6	52.9	41.9	29.8	23.4	19.4	12.9	10.7	5.55
1.70V	198	122	72.2	52.7	41.5	29.7	23.3	19.3	12.8	10.6	5.51
1.75V	184	117	71.1	52.0	41.2	29.4	23.1	19.2	12.7	10.5	5.47
1.80V	164	111	68.7	50.8	40.2	28.7	22.6	18.8	12.5	10.4	5.37
1.85V	138	101	64.0	48.1	38.1	27.3	21.6	18.0	12.1	9.91	5.15

Constant Power Discharge Characteristics Unit:W (25°C ,77°F)

F.V/Time	15MIN	30MIN	60MIN	90MIN	2HR	3HR	4HR	5HR	8HR	10HR	20HR
1.60V	2197	1389	845	622	491	347	271	224	153	128	67.3
1.67V	2117	1370	843	619	488	344	270	223	152	127	66.6
1.70V	2069	1361	837	615	487	342	268	222	149	124	65.6
1.75V	1944	1327	828	611	482	341	265	221	148	123	65.3
1.80V	1753	1261	798	598	472	334	262	217	147	122	65.0
1.85V	1516	1177	748	569	447	320	252	210	144	120	62.6

Trickle (or Float) Service Life

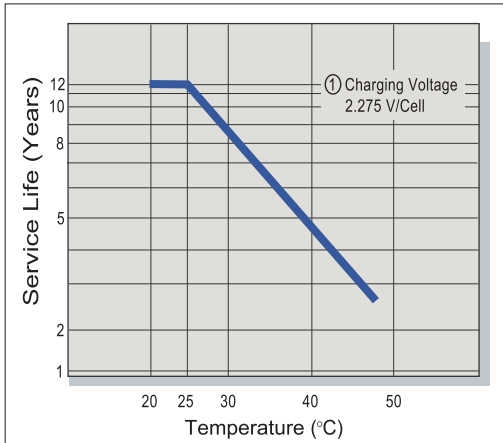

Capacity Retention Characteristic

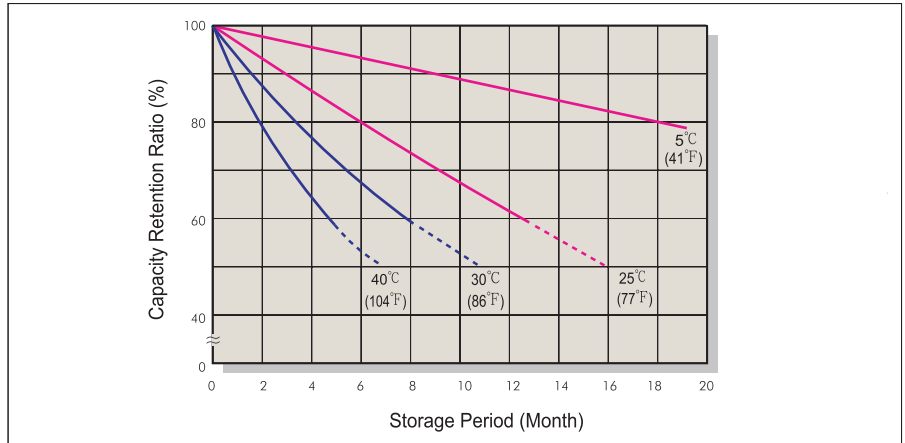

Battery Voltage and Charge Time for Standby Use

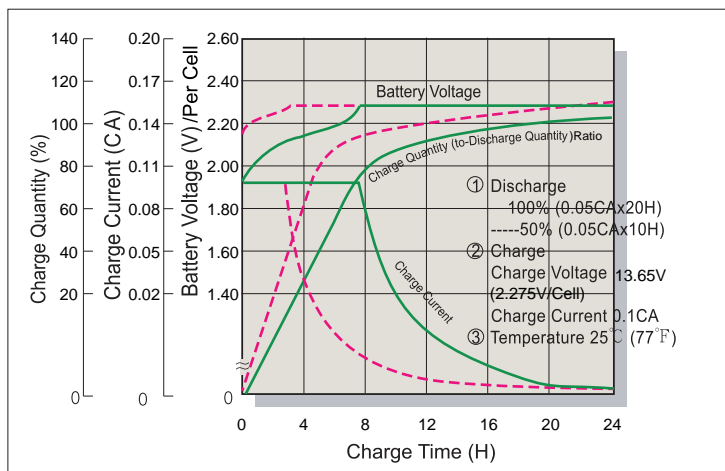

Cycle Service Life

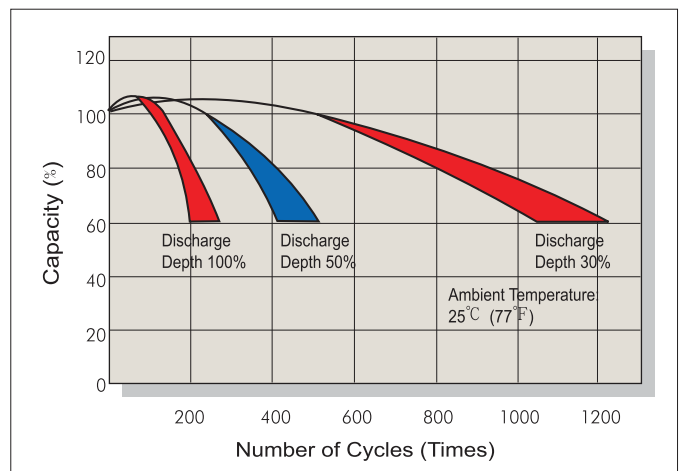

Battery Voltage and Charge Time for Cycle Use

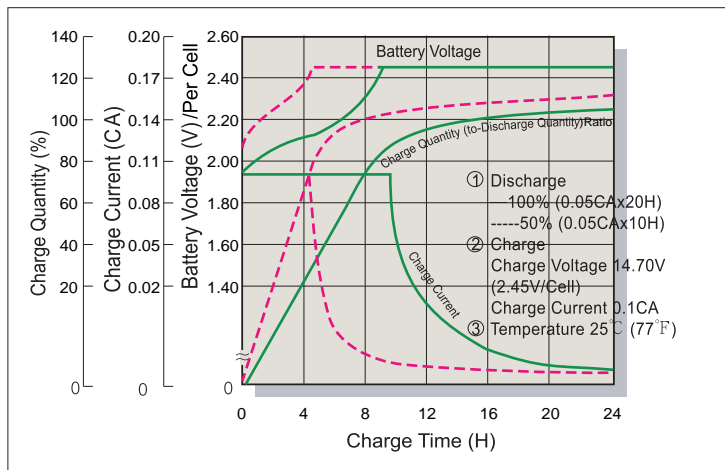

Terminal Voltage (V) and Discharge Time

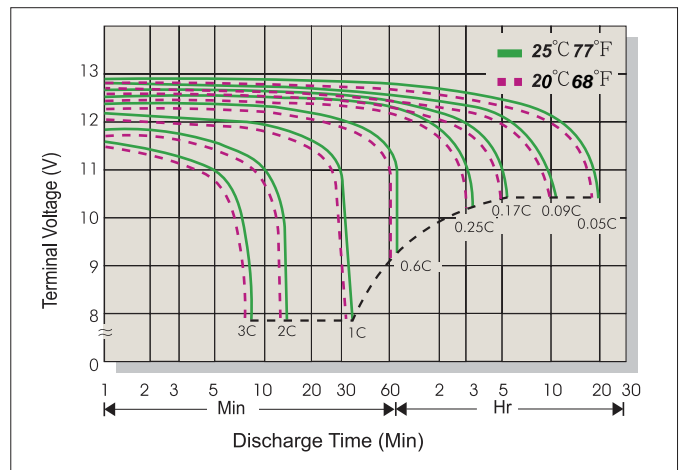

Charging Procedures

Application	Charge Voltage(V/Cell)			Max.Charge Current
	Temperature	Set Point	Allowable Range	
Cycle Use	25°C(77°F)	2.45	2.40~2.50	0.3C
Standby	25°C(77°F)	2.275	2.25~2.30	

Discharge Current VS. Discharge Voltage

Final Discharge Voltage V/Cell	1.75	1.70	1.60	1.30
Discharge Current(A)	0.2C>(A)	0.2C<(A)<0.5C	0.5C<(A)<1.0C	(A)>1.0C

Sales Office URL: WWW.CSB-BATTERY.COM

GLOBAL HQ
CSB BATTERY CO., LTD. (TAIWAN)
 Tel : +886-2-2880-5600
 Fax : +886-2-2888-3300
 mail : service@csb-battery.com.tw

BEIJING OFFICE. (CHINA)
CSB BATTERY TECHNOLOGIES (BEIJING) CO., LTD.
 Tel : +86-10-5820-5336/5338
 Fax : +86-10-5820-3053
 mail : chinasl@csb-battery.com

AMERICA HQ
CSB BATTERY TECHNOLOGIES INC. (U.S.A)
 Tel : +1-817-244-7777/1-(800)3-CSB-USA(272872)
 Fax : +1-817-244-4445
 mail : csb@csb-battery.com

SHANGHAI OFFICE. (CHINA)
CSB BATTERY LOGISTIC (SHANGHAI) CO., LTD.
 Tel : +86-21-5046-1622/5046-0833
 Fax : +86-21-5064-1046
 mail : chinasl@csb-battery.com

EUROPE HQ
CSB Battery Europe BV.
 Tel : +31(0)-180-418-140
 Fax : +31(0)-180-418-327
 mail : eurosales@csb-battery.eu

SHENZHEN OFFICE. (CHINA)
CSB BATTERY LOGISTIC (SHANGHAI) CO., LTD.
 Tel : +86-755-8831-6488/6396/6356
 Fax : +86-755-8831-6548
 mail : she@csb-battery.com.cn